

Basing the Constructional Parameters of the Plug-Softener that Works Between the Garden Rows

D. B. Irgashev

Ph.D., Karshi Institute of Engineering and Economics

Abstract: The article provides brief information about the current state of tillage in our country and tillage machines used in foreign countries. In addition, there is a brief description of the current problems and solutions of tillage technologies and agro technical requirements of tillage. Today's tillage tools used in horticulture and their disadvantages and advantages of energy-efficient soil-protecting inclined column plow-softener are theoretically based on its parameters. The parameters of the inclined column plug softener were based on the results obtained from the theoretical experimental studies.

Key points: gardening, soil, tillage, plough, tillage, labor, fuel, fall, plough, depth, softener, distance, indicator, fertility, alien

Introduction

Horticulture is one of the main sectors that determines the economy of the Republic of Uzbekistan and brings a lot of income. Without developing this industry on a scientific basis, it is impossible to satisfy the demand for fruit products of the population and our industry. Therefore, it is necessary to thoroughly study the agricultural sector, including horticulture, to find out what problems have occurred and to find a positive solution to them. Air and soil temperature are extremely important for fruit trees. During the growth, development and formation of crops of each variety and species of trees, all physiological processes take place in a certain amount of soil and air temperature.

In tillage, the main focus should be on protecting the soil and restoring its fertility. For this purpose, traditional and resource-saving methods of soil cultivation are used. Which method to use depends on local conditions. In intensive farming, minimum tillage is considered a key factor that preserves the soil's potential fertility and increases its effective productivity, protects against erosion and improves humus balance, reduces nutrient and water losses, and shortens the duration of field work.

Currently, the following practical directions of minimal processing are designed:

- reduce the number and depth of main, pre-plant and inter-row treatments using herbicides;
- Replacing deep machining with surface and shallow machining using a wide range of tools and machines that provide high-quality machining in one pass;
- combining several technological operations into one work process using combined units that grind the stalks and bury them locally, fertilize and plant seeds at the same time as soil cultivation
- Reduce the area under cultivation by using herbicides and pre-plant strip tillage when planting grass crops;
- improve the quality of the plow by perfecting the basic soil processing technology and technical equipment and, as a result, reduce the number of additional operations to prepare the soil for planting. In the traditional way, the soil is plowed deep (more than 20 cm) with a plow and the main cultivation is done.

RESEARCH MATERIALS AND METHODOLOGY

Later, the soil is cultivated shallowly with various machines such as harrows, cultivators, milling machines. During plowing, the top layer of the soil is sheared off and moved to the side, turned to a certain angle and turned over. As a result of overturning, the soil layer is deformed and crushed, the structure of the soil is restored, weed seeds and remains and insects are sanded, and the bottom layer of the soil, i.e. humus, is removed from the surface of the earth. Weeds can be drastically reduced by using traditional methods, deep and very deep (27 cm and more) plowing. Tillage has a negative effect on the soil, because the organic matter that is brought to the surface of the earth decomposes under the influence of sunlight and other factors, the carbon contained in it can fly into the atmosphere, and soil erosion can increase. This reduces soil fertility. For example, if the specific resistance of the soil (moisture 16-18%) recommended for overturning is minimal, the moisture resistance of the dry soil (5-6%) can increase by 2 times. When such land is plowed with a plow, large clods are formed, which are very expensive to grind later.

When the land is cultivated, conditions are created for favorable regimes of the soil (water, air, heat and nutrients), that is, the structure of the arable layer and its granularity change;

the nutrients in the lower layer of the soil rise up, and its cycle cycle and microbiological processes are accelerated;

weeds are eliminated; organic-mineral fertilizers and manure are added to the soil;

pests and pathogens of crops living in the surface layer of the soil or plant residues are eliminated;

preparation of the land for planting crops, harvesting and furrowing, and inter-row cultivation in crop care;

work such as weeding is done.

The soil of the land where the repeated crop is planted must be well compacted, otherwise it will take a lot of labor and fuel to grind it goes. Visually, the fallow area should not be more than 0.2% of the total area, otherwise the land is considered unsatisfactory. When the land is plowed in the fall, the water between the furrows sometimes freezes and sometimes melts on cold and warm days, which ensures that the furrows are crushed. A lot of moisture accumulates on the plowed land in autumn; favorable conditions for microbiological processes are created. An opportunity is created for plant residues to be buried and rot. It will be much easier to prepare the land plowed in the fall for planting crops in the spring. High-quality autumn plowing increases crop yield by 10-20% compared to spring plowing, the harvest is early and of good quality.

In order for the vine to grow and produce at the same rate, it is necessary to cultivate the soil in spring-summer and autumn (to improve the water and weather regime, remove weeds and protect the vines from winter frosts). Cultivating the soil at a depth of 25-30 cm in the fall helps to accumulate a large amount of moisture in the soil by spring, and helps to eliminate weeds.

If the vineyard was not cultivated in the fall, the land is plowed simultaneously with the mechanized opening of the vines in the spring. After the vines are opened, they are cultivated or harrowed to level the soil between the rows. Cultivation is carried out 3-4 times at a depth of 10-12 cm between the rows in order to eliminate weeds in the soil and maintain moisture in the soil during the growing period. Cultivation should be done after each irrigation and after each heavy rain in dry land vineyards.

During the spring and summer, the soil around the vine bush is treated with a device equipped with a NYu-18 plow to create a soft layer and remove weeds. Until now, some of the vines are grown on the ground, in such vineyards, the soil is plowed in the spring and softened after summer watering. As a result of multiple passes of mechanisms and irrigation, the soil between vine rows is strongly compacted, which negatively affects the growth and productivity of vine bushes. In MPV machines, at the same time as fertilizing, the soil should be softened annually between each row along three tracks, because in this case the side softeners sink into the soil 35-40 cm deep and do not damage the root system much, and the central softener 55-60 sinks to a depth of cm. If the work is carried

out with a MPV machine, which loosens three tracks at a depth of 55 cm, then it is necessary to loosen between the rows.

In such softening, the water-air regime of the soil improves, and the root system grows well. As a result, productivity increases by 35-40%. In dry land vineyards, the soil is deeply loosened in the spring, then loosened to a depth of 18-20 cm during the growing season. The vine is softened at a depth of 18-20 cm during maintenance work. Current maintenance works are performed with MPV, NYu-18, UOM-50, pneumatic current breakers.

In order to obtain a high yield from gardens, it is necessary to use new technologies and techniques in the main processing of rows between rows, to complete the plowing of garden rows in accordance with the established agrotechnical requirements in a timely manner and with high quality. PN-3/4-35, PN-4-25, PS-4-30, PS-3-30, PS-4-30A, PSV, which are currently used for plowing open fields in all horticultural farms of our country -120-50, PLS-5-25A, PV-1,7, and PSG-3-30A brand horticultural plows are used for plowing between garden rows. In recent years, in countries where the horticultural sector of agriculture has developed (China, India, Italy, Korea, Turkey, Poland, Russia, USA, Canada, Belgium, France, Germany), along with horticultural machines, garden rows in the cultivation of the soil, step deep loosening devices and combined gardening machines are effectively used. In the following years, as a result of research carried out in the United States of America, Great Britain, Norway, the Netherlands, Germany, Russia and other countries, the side profile of a parabola, S-shaped columns and a curved-helicoid working surface for tillage without a tipper. parabolic working bodies in the cross-vertical plane, Y-shaped, X-shaped working bodies of the "paraplau" type (Volgograd IICHB, MDAU) were created. The advantage of these working bodies over the previous ones is that they can be used without turning the soil, which allows to maintain soil fertility and save energy. Taking this into account, the parameters of the plug-softener with an arrow-shaped structure, which works between garden rows without turning, were based. The parameterization of the plug softener is to reduce the number of soil treatments between garden rows and to soften the soil at the level of agrotechnical requirements without damaging tree roots while consuming less energy.

DISCUSSION

During the working process of the machine, the softening claw works the soil at a depth $a_1 > a$ along the axis of symmetry of the weapon. In this case, the softening claw deforms the soil during its work and softens it. The cross-section of the deformation zone is trapezoidal. The softener operates under closed cutting conditions. The blade of the improved tilting column softener located in the left and right sections penetrates the driving layer and breaks the soil into small pieces. The resulting cracks spread to the soil surface at an angle ψ_k . After that, the blade of the column enters the soil zone deformed by the chisel. The soil separated by the chisel rises along its surface and falls on the blade.

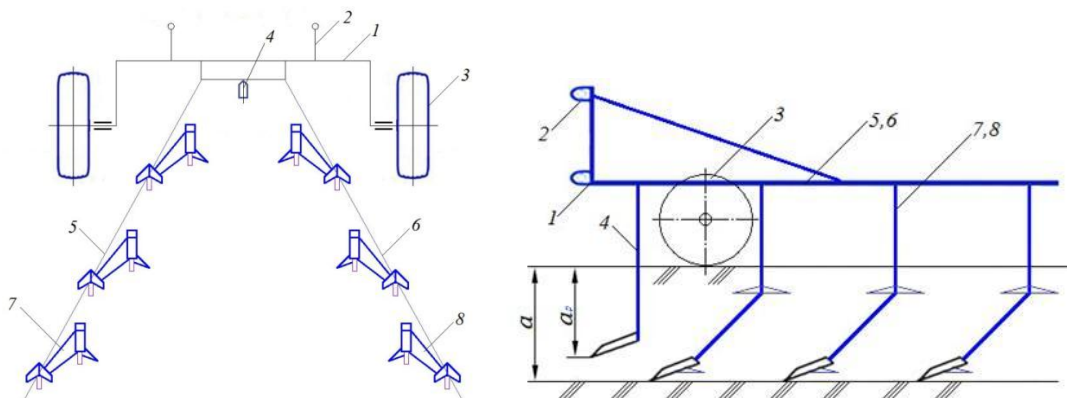

1-frame; 2-hanging device; 3-base wheels; 4-softening paw;
5 and 6 – frame of left and right sections; 7-softeners with slanted
columns bent to the right; 8-bent to the left inclined pillar softeners;

Figure 1. Scheme of the improved plug softener: a- top view; b- side view;

In this case, the soil is bent and stretched in longitudinal and transverse sections, which causes it to break up rapidly. In the process of work (Fig. 1), the bottom softener 5, which is covered with a cone, softens the scythe at the bottom of the soil layer and the bottom of the egate. As a result, the height of the scythe at the bottom of the egate is significantly reduced. The bullet-shaped softener 2 installed on the column 1 softens the upper layer of the column softened zone of the soil to a thickness of a_{yy} . Further working bodies soften the soil in the same order. As a result, the soil is compacted at the level of agrotechnical requirements in the coverage width of the machine and the height of the scythe is provided at the bottom of the field.

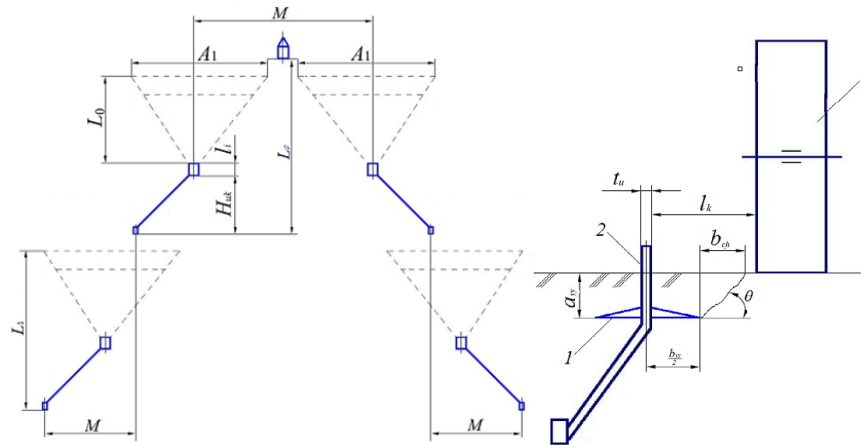

Figure 2. The scheme for determining the longitudinal distance between the working bodies with an inclined column and the transverse distance between the working body with the inclined column of the support wheel

When placing working bodies with an inclined column in the longitudinal direction, we determine the condition of eliminating their clogging with plant residues and soil. In this case, the sliding plane of the blade deformed by the punch of the next working body should not reach the structural elements of the previous working body.

$$L_p = L_1 \geq l_1 + l_i \cos \alpha_i + H_{uk} \operatorname{tg} \beta_b \quad (1)$$

The length of the deformation zone can be determined by the following expression

$$l_1 = a_{\max} \operatorname{ctg} \psi_b, \quad (2)$$

We determine the transverse distance between the tilt column softener and the support wheel on the condition that the soil deformed under the influence of the upper softener of the working body does not reach the support wheel, that is, the support wheel moves from the unsoftened area of the field

$$l_k \geq \frac{b_{yy}}{2} + a_{yy} \operatorname{ctg} \theta, \quad (3)$$

In the experiments, the longitudinal distance between the plug-softening working bodies was changed from 0 cm to 75 cm at intervals of 15 cm. In this case, the transverse distance between them was 60 cm, the processing depth was 28 cm, the coverage width of the upper softener was 22 cm, and the coverage width of the lower softener was 8 cm. Experiments were conducted at speeds of 6 and 9.0 km/h.

As a criterion for evaluating the performance of the device, the level of soil compaction in the area it works and the resistance of the working bodies to gravity were accepted. In the experiments, two working bodies were installed on the device.

RESEARCH RESULTS

The obtained results show that at both speeds of the device, increasing the longitudinal distance between the working bodies with a strong column from 0 to 75 cm increases the level of

compaction of the soil according to the convex parabola, and the resistance to traction increases according to the law of the concave parabola. After the longitudinal distance exceeds 60 cm, these indicators almost do not change.

At values of the longitudinal distance less than 45 cm, it was observed that the soil and plant residues were stuck between the neighboring working bodies in the direction of movement of the device. In this case, under the influence of the next working body, the deformation propagation zone of the soil reaches the forward working body. When the longitudinal distance increases from 45 cm, the clogging of the soil is eliminated. Clogging of plowshares between the working organs worsens the level of soil compaction. Therefore, as the longitudinal distance L increases, the level of soil compaction improves.

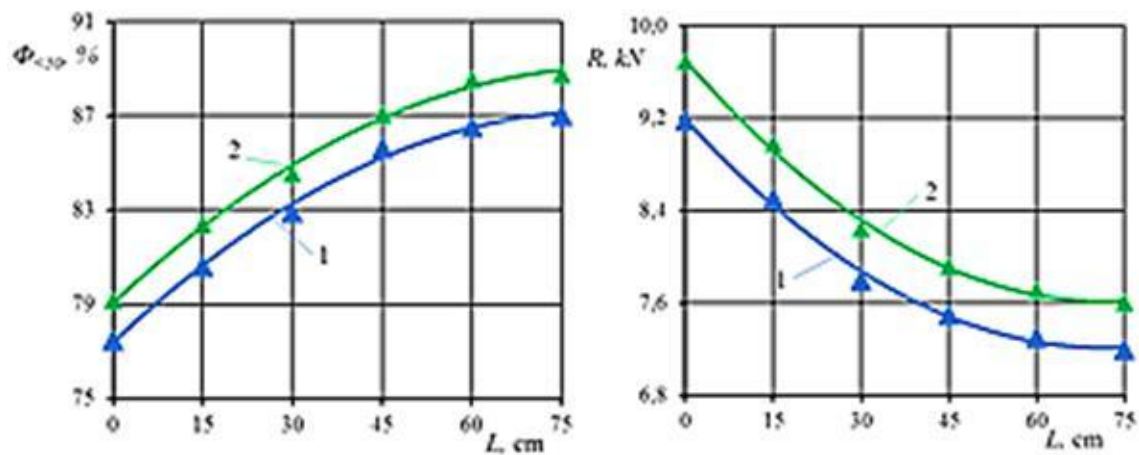

Figure 3. The level of soil compaction ($\Phi_{<50}$) and the traction resistance (R) of the inclined column working bodies depending on the longitudinal distance (L) between them o'zgarishi

The curves depicted in figure 3 can be represented by the following empirical formulas determined by the method of least squares:

according to soil compaction

$$V_1=6 \text{ km/h when } y = -0,0015x^2 + 0,2406x + 77,377 \quad (R^2 = 0,9956), \text{ \%}; \quad (4)$$

$$V_2=9,0 \text{ km/h when } y = -0,0014x^2 + 0,2375x + 79,055 \quad (R^2 = 0,9959), \text{ \%}. \quad (5)$$

in terms of tensile strength

$$V_1=6 \text{ km/h when } y = 0,0004x^2 - 0,0553x + 9,1874 \quad (R^2 = 0,9923), \text{ kN}; \quad (6)$$

$$V_2=9,0 \text{ km/h when } y = 0,0004x^2 - 0,0584x + 9,7019 \quad (R^2 = 0,9963), \text{ kN}; \quad (7)$$

Thus, in order to ensure the minimum traction resistance and required level of soil compaction, the longitudinal distance between the working bodies should be at least 60 cm.

Conclusion. According to the results of experimental studies, equipping the working bodies of the plug-softener with an inclined column with the upper and lower softeners of the universal claw type and the arrow-shaped claw type ensures the required level of work quality. According to the results of experimental studies, the transverse distance between the tracks of the inclined column working bodies equipped with upper and lower softeners should be 30 cm, and the minimum longitudinal distance between them should be 60 cm.

REFERENCES:

1. Ibrat Ismoilov, Dilmurod Irgashev. Justification of the Mutual Arrangement of the Working Bodies of the Machine for Preparing the Soil for Sowing Melons and Gourds Under the Tunnel Film. International Journal of Innovations in Engineering Research and Technology
2. D. Irgashev, O. Mamadiyorov, M. Xidirov. Technical analysis of the disk working bodies that work the soil and them working between the garden row. Science and innovation

3. D. Irgashev. Improved plug-softener technology for working between garden rows. Science and innovation
4. D.B.Irgashev. The effect of the upper softener of the sloped column working body working on the soil of garden fields on the energy indicators// Science and innovation international scientific journal volume 2 issue 8 August 2023 UIF-2022: 8.2 | ISSN: 2181-3337 | SCIENTISTS.UZ
5. Daniyarov U., Suvonova A., Soxibova N. Creation of inbred systems with a choice of plus and minus on the viability of silkworms with the best combination value //Результаты научных исследований в условиях пандемии (COVID-19). – 2020. – Т. 1. – №. 06. – С. 22-28.
6. Dilmurod Irgashev¹, Sanjar Toshtemirov¹, Farmon M. Maiviatov^{1,2}, and Bayramali Muqimov² Placement of working bodies on the frame of the tool plow-ripper//E3S Web of Conferences 390, 01036 (2023) <https://doi.org/10.1051/e3sconf/202339001036> AGRITECH-VIII 2023
7. Irgashev D.B., Tovashov R.X., Sadikov A.R, Mamadiyrov O.T. Technical Analysis of Plug Software When Working Between Gardens // International Journal of Advanced Research in Science, Engineering and Technology. – Vol. 9, – Issue 5, 2022.
8. Ismailovich B. C. et al. Technology of Disease Removal, Processing and Treatment of Mulberries and Nutritional Mulberries in Spring //Eurasian Medical Research Periodical. – 2022. – Т. 7. – С. 96-98.
9. Kh Ravshanov, Kh Fayzullaev, I Ismoilov, D Irgashev, S Mamatov, Sh Mardonov. The machine for the preparation of the soil in sowing of plow crops under film. IOP Conference Series: Materials Science and Engineering
10. Khayriddin Fayzullaev, Farmon Mamatov, Bakhadir Mirzaev, Dilmurod Irgashev, Sodik Mustapakulov, Akram Sodikov. Study on mechanisms of tillage for melon cultivation under the film E3S Web of Conferences
11. Mirzaeva Y., Khujamshukurov N., Sokhibova N. Efficiency and quality indicators of in vitro propagation of high-yielding mulberry varieties and hybrids //Результаты научных исследований в условиях пандемии (COVID-19). – 2020. – Т. 1. – №. 06. – С. 50-56.
12. Sokhibova N. S. et al. STUDYING THE ECONOMIC CHARACTERISTICS OF MULBERRY SEEDLINGS PROPAGATED IN A NEW WAY IN THE TASHKENT REGION //European International Journal of Multidisciplinary Research and Management Studies. – 2022. – Т. 2. – №. 06. – С. 106-110.