

## Relevance of the Feed Delivery Device to the Granulator Device

Atkham Borotov, Jakhongir Sadullaev, Narmurod Sattarov

“Tashkent Institute of Irrigation and Agricultural Mechanization Engineers” National Research University, 39, Street Kari Niyazi, Tashkent, 100000, Uzbekistan

**Abstract:** Small livestock, poultry, rabbit and fishing farms are growing every day in our country. Based on this, for the rapid development of farms, there is a need to strengthen the feed base and the necessary equipment for preparing feed. Based on this, research is being carried out on the development of small-tonnage quantifiers-loaders for the development of fisheries, poultry farming, livestock farming and rabbit farming.

**Key points:** Equipment, poultry farming, fishing, rabbit farming, pellets, farmer, farm.

**Introduction.** The production of livestock, rabbit breeding, fishing and poultry products is important in our country based on the number of people today. Based on this, it is urgent to develop these sectors, to provide adequate quality and nutritious food products.

Currently, for the development of livestock, rabbit breeding, fishing and poultry breeding, the expansion of feed bases, the creation of scientifically based modern devices for the development of foreign and domestic competitive quality products is of great importance. Pellets for fish and poultry are being prepared in large production enterprises. In our republic today more and more are imported from various foreign countries, including China and Russia [1-3].

Due to the consumption of a lot of metal in the preparation of these devices, due to their large size, they are used in livestock farming, rabbit farming, fishing and poultry farming, i.e. in farms with a large number of fish, cattle, rabbits and poultry, and a small number of heads . use in small farms does not justify itself. It is observed that the quantity loaders imported from abroad require a lot of energy and are expensive, and the costs of technical maintenance will increase over time. Based on these, scientific research is being conducted on the development of a small-sized quantifier-loader device.

**Problem setting.** Development and comprehensive support of livestock, rabbit breeding, fishery and poultry breeding in our country, introduction of advanced technologies and innovative developments in the field, deepening of processing of livestock, rabbit, fish and poultry products, their types and export Priority tasks for the development of livestock, rabbit breeding, fishery and poultry industry were given in order to expand the region [4-5].

Based on the information given above, today's available devices were studied and analyzed.

**Materials and methods.** In order to study the needs of the quantity-loader in our country, to study the state of meat production from livestock, rabbit, fishery and poultry farms, the feed and composition of feed required for them, their different sizes and colors indicators were determined in consultation with experts working in feeding and feeding and relying on their recommendations.

Necessary information on quantifier-loaders was obtained from scientific journals and Internet databases in Scopus and Web of Science, and their constructions were analyzed using SWOT

methods, morphological synthesis and ARIZ methods, and their disadvantages and advantages were determined.

**Results and discussion.** Based on the results of the above research and based on the specified requirements, a constructional-technological scheme of the quantifier-loader device used in the granulated feed production line, which is being developed for small livestock, rabbit, fishery and poultry farms, was developed (Fig. 2).

The operation scheme of the loader-loader device includes the handling of the load in the loading device, its transportation inside the case, and the unloading device falls. In this case, the load changes character twice. In the loader, it moves down at an angle or vertically until it interacts with the helix surface of the auger. After being caught by the auger, the load moves along the axis of the auger unloading device, the trajectory of its movement can be vibrating and delivers it to the mixer at a fixed speed along the spiral line. A regulator is installed to regulate the speed.

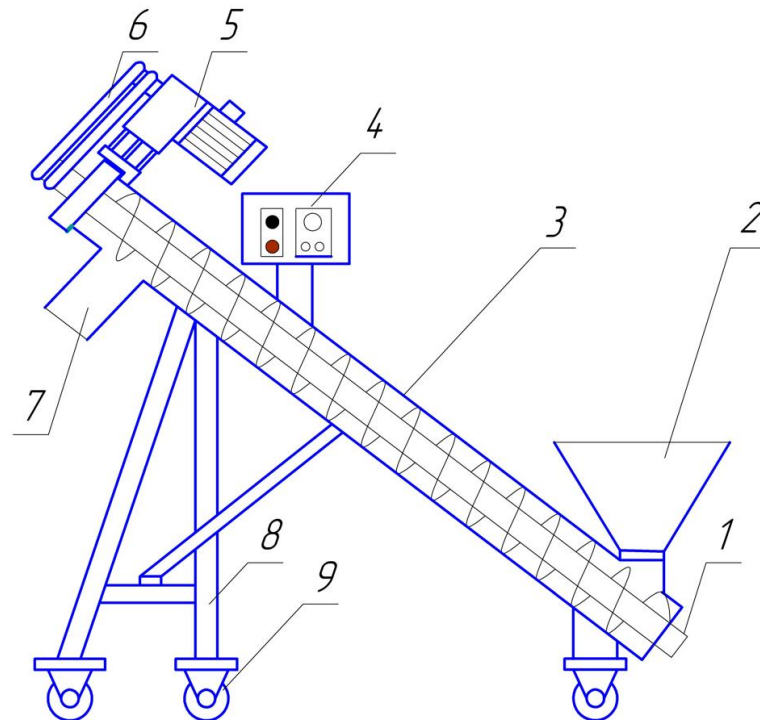

1- shaft; 2-bunker; 3-pipe; 4-quantifier; 5-electric motor; 6-belt transmission;  
7-downpipe; 8-base column; 9-wheel.

**Figure 1. Scheme of a small-sized quantizer-loader.**

Now, based on the developed scheme, a pilot copy of the device is being prepared, and theoretical and experimental studies are being conducted to justify the optimal parameters and operating modes of its working parts. At the end of the research, economic tests of the device will be conducted, the quality of work and technical and economic indicators will be determined and it will be put into production.

**Summary.** The role of rationed feed is important in livestock, rabbit breeding, fishing and poultry farming. Due to the small size of livestock, poultry, fishery and rabbit farms in Uzbekistan, it is not possible to use granulation lines and their devices developed for large farms. Based on this, a measuring-loader device was developed that delivers small-sized raw materials to the granulator used in the granulated feed production line, which is being developed for small livestock, poultry and fish farms. When using this device, it is possible to deliver quality raw materials in the required quantity, saving energy and resources.

## References

1. Characteristics of the screw conveyor: [Electronic resource]: Mode available: <http://www.findpatent.ru/patent/231/2312807.html>. Data access: 25.06.2013.
2. Characteristics of a screw conveyor: [Electronic resource]: Mode accessible: <http://www.oriond.ru/transporter-shnekovy-konveyer>. Data access: 26.06.2013.
3. Raschet proizvoditelnosti screw conveyor: [Elektronnyy resurs]: Mode dostupa: [http://konveieri.ru/konveyer vintovoy](http://konveieri.ru/konveyer-vintovoy). Data access: 28.07.2013.
4. Bychkov Ivan Evgenevich, Bychkova Tatyana. Modelirovanie parametrov shnekovogo transportera-raspredeletelya, *Bryanskiy gosudarstvennyy agrarnyy universitet*. 2022.
5. Dean Todorov, Bozhidar Kolev. Preliminary studies on horizontal screw-type dispenser with and without a compensating screw-conveyor device. *Agrarian and Industrial Faculty, Department of Agricultural Machinery, "Angel Kanchev" University of Ruse, Bulgaria*. 2019.